

Unit 6
Belturbet Business Park
Creeny
Belturbet
Co. Cavan
H14AY94

T: +353 49 9522236
E: info@alantraynor.com
W: www.alantraynor.com

2nd Floor
67-70
Meath St
Dublin 8
D08XY53

T: +353 1 6750850
E: dublin@alantraynor.com
W: www.alantraynor.com



Alan Traynor
Consulting Engineers Ltd.



23-121

CAVAN COUNTY COUNCIL

**PROPOSED HOUSING DEVELOPMENT AT
CHAPEL LANE, COOTEHILL,
Co. CAVAN**

**Foul Water, Surface Water and Water Supply
Calculations & Details**



Table of Contents

1.0	Introduction	2
1.1	Site Description	2
2.0	Surface Water Drainage	2
2.1	Surface Water Drainage - Existing.....	2
2.2	Surface Water Drainage – Proposed.....	2
3.0	Foul Drainage	3
3.1	Foul Drainage – Existing.....	3
3.2	Foul Drainage – Proposed	3
4.0	Water	3
4.1	Water - Existing.....	3
4.2	Water - Proposed.....	3
Appendix A	- Surface Water Calculations & Details	
Appendix B	- Foul Water Calculations	
Appendix C	- Irish Water Confirmation of Feasibility	



1.0 Introduction

Alan Traynor Consulting Engineers Ltd have been engaged by Cavan County Council to carry out engineering services design for the proposed 13-unit residential development at Chapel Lane, Cootehill, Co. Cavan. This report addresses the foul, surface water drainage and water supply for this application.

1.1 Site Description

The site is a greenfield site but the majority of it has a gravel finish as it acts as a carparking area for nearby community facilities. The site has an area of 0.25 hectares and is located at Chapel Lane, Cootehill, just to the east of the junction of Chapel Lane and Bridge Street. The site is adjoined by a service station to the south west, 2 storey dwellings to the south, a church and hall to the south east, a hall and GP Doctors to the north, and a small dwelling and commercial unit to the north west.

2.0 Surface Water Drainage

2.1 Surface Water Drainage - Existing

There is no existing surface water drainage on site.

2.2 Surface Water Drainage – Proposed

It is proposed to collect all surface water runoff from the site in a suitably sized sewer network and discharge it to the public surface water sewer approximately 90m to the east of the site by laying a new sewer along Chapel Lane as far as the connection point. An attenuation tank within the site, with a capacity of 37.33m³, will retain surface water from the site when the flow exceeds the limit of the hydro-brake fitted on the discharge pipe, which is 5l/s. The attenuation tank is sized to cater for a 1 in 100-year storm event with an additional 20% allowance for climate change. The Qbar value for the site was calculated using the UKsuds website. As recommended when the Qbar value is calculated at less than 5l/s the restricted value shall be set at 5l/s to prevent buildup of vegetation in the pipework. The surface water runoff from the carpark area will pass through a bypass interceptor prior to being discharged to the public surface water sewer. Please refer to drawing 23-121-100 for the surface water sewer layout and Appendix A for calculations.



3.0 Foul Drainage

3.1 Foul Drainage – Existing

There is no existing foul sewer on the site.

3.2 Foul Drainage – Proposed

It is proposed to collect the foul water from the 13 new units using a suitably sized network and discharge it to the public foul water sewer approximately 90m to the east of the site by laying a new sewer along Chapel Lane as far as the connection point. Please refer to drawing 23-121-100 for the foul water sewer layout, Appendix B for calculations, and Appendix C for Irish Water Confirmation of Feasibility.

4.0 Water

4.1 Water - Existing

There is no watermain connection on the site.

4.2 Water - Proposed

It is proposed to make a 100mm diameter connection to the existing 150mm diameter watermain in Bridge Street as recommended in the Irish Water Confirmation of Feasibility. A new 100mm HDPE SDR17 watermain will be laid in Chapel Lane and be terminated in a loop as per Irish Water requirements. All 13 units will be served by this new watermain. Sluice valves, scour valves, air valves and hydrants will be constructed on the proposed watermain as required by Irish Water Code of Practice and Standard Details. Please refer to drawing 23-121-102 for the watermain layout and to Appendix C for the Irish Water Confirmation of Feasibility.

Appendix A – Surface Water Calculations & Details

Storm sewer loadings for Development at Chapel Lane, Cootehill, Co. Cavan

DATA		STORM WATER FLOW Modified Rational Method						Cr = 1.3 Cv = 0.7		SEWER DESIGN Ks = 0.60									
SEWER REFERENCE		Roads	Roofs/yards	Impervious Area	Cumulative Impervious Area	Rainfall : I (mm/hr)	Storm Water Flow	Size of drain (mm)	Gradient (1 in x)	Length (m)	Capacity (l/sec)	Pipe full Velocity (m/sec)	Actual Velocity (m/sec)	Half full velocity (m/sec)	Max Velocity (m/sec)	Depth of flow (mm)	Reserve capacity (l/sec)		
From Manhole	To Manhole	Area A1	Area A2				$Q=Ap*I*Cr*Cv*2.78$ l/sec												
1	2	3	4	5	6	7	8	9	10	11	12	13	14	15	16	17			
S1	S2	0.016	0.024	0.041	0.041	50.00	5.13	225	200	26.263	36.57	0.92	0.65	0.92	1.04	56.25	31.43		
S2	S3	0.032	0.035	0.067	0.108	50.00	13.62	225	200	51.139	36.57	0.92	0.85	0.92	1.04	94.92	22.94		
S3	S5	0.005	0.000	0.005	0.113	50.00	14.25	225	200	14.365	36.57	0.92	0.86	0.92	1.04	97.56	22.32		
S4	S5	0.044	0.000	0.044	0.044	50.00	5.51	225	22	4.840	111.35	2.80	1.47	2.80	3.18	33.84	105.85		
S5	S6	0.000	0.000	0.000	0.156	50.00	5.00	225	200	13.060	36.57	0.92	0.65	0.92	1.04	56.25	31.57		
S6	S7	0.000	0.000	0.000	0.000	50.00	5.00	225	200	17.800	36.57	0.92	0.65	0.92	1.04	56.25	31.57		
S7	S8	0.000	0.000	0.000	0.000	50.00	5.00	225	42	20.194	80.44	2.02	1.13	2.02	2.29	37.79	75.44		
S8	Sext	0.000	0.000	0.000	0.000	50.00	5.00	225	22	61.085	111.35	2.80	1.43	2.80	3.18	32.52	106.36		

5.00 litres/sec achieved by means of a Hydrobrake



Alan Traynor Consulting Ltd
 Belturbet Business Park
 Belturbet
 Co. Cavan

Job Title

CHAPEL LANE COOTEHILL

Revision

A

Job No:

23-121

Page:

C/01

Section:

Attenuation tank

Prepared By:

JOR

Date:

18/10/2023

GENERAL DATA

site location: **Ireland**
 60 min rainfall depth of 5 year return period 'R' [mm] = **16**
 M5-60 to M5-2d rainfall ratio 'r' = **0.30**
 proposed discharge rate 'v₁' [litre/s] = **5.00**
 proposed discharge rate 'v₂' [litre/s] = **5.00**
 allowance for climate change: **20%**

SUMMARY OF CALCULATIONS

required storage volume for discharge rate 'v₁' = **24.67** m³
 required storage volume for discharge rate 'v₂' = **37.33** m³

AREA DATA

	impermeability [%]	effective area [m ²]
impermeable area 'A ₁ ' [m ²] = 1564	100.00	1564
landscaping and/or green roof area 'A ₂ ' [m ²] = 0	25.00	0
other partially permeable area 'A ₃ ' [m ²] =	50.00	0

AREA DRAINED TO ATTENUATION TANK = 1564 m²

REQUIRED STORAGE VOLUME PER RAINFALL DURATION FOR DISCHARGE RATE v₁

rainfall duration [min]	rainfall factor Z1	M5-D rainfalls [mm]	M10-D			M20-D			M30-D			outflow from attenuation tank [m ³]	required storage [m ³]
			Z2	rainfalls [mm]	inflow [m ³]	Z2	rainfalls [mm]	inflow [m ³]	Z2	rainfalls [mm]	inflow [m ³]		
5	0.34	6.30	1.18	6.90	10.79	1.36	8.30	12.98	1.45	9.20	14.39	1.50	12.89
10	0.49	8.70	1.18	9.60	15.01	1.38	11.50	17.99	1.48	12.80	20.02	3.00	17.02
15	0.59	10.30	1.19	11.20	17.52	1.39	13.60	21.27	1.49	15.10	23.62	4.50	19.12
30	0.77	12.90	1.20	14.20	22.21	1.39	17.10	26.74	1.49	18.90	29.56	9.00	20.56
60	1.00	16.30	1.20	18.00	28.15	1.39	21.40	33.47	1.49	23.60	36.91	18.00	18.91
120	1.25	20.50	1.19	22.80	35.66	1.38	26.90	42.07	1.47	29.60	46.29	36.00	10.29
240	1.57	25.80	1.18	28.90	45.20	1.37	33.80	52.86	1.46	37.00	57.87	72.00	0.00
360	1.79	29.60	1.18	33.20	51.92	1.36	38.70	60.53	1.44	42.10	65.84	108.00	0.00
600	2.13	35.00	1.18	39.00	61.00	1.35	45.30	70.85	1.43	49.30	77.11	180.00	0.00
1440	2.86	47.00	1.16	53.20	83.20	1.31	61.00	95.40	1.39	65.90	103.07	432.00	0.00

* Z2 is a growth factor from M5 rainfalls

REQUIRED STORAGE VOLUME PER RAINFALL DURATION FOR DISCHARGE RATE v₂

rainfall duration [min]	rainfall factor Z1	M5-D rainfalls [mm]	M10-D			M30-D			M100-D			outflow from attenuation tank [m ³]	required storage [m ³]
			Z2	rainfalls [mm]	inflow [m ³]	Z2	rainfalls [mm]	inflow [m ³]	Z2	rainfalls [mm]	inflow [m ³]		
5	0.34	6.30	1.18	6.90	10.79	1.45	9.20	14.39	1.89	12.60	19.71	1.50	18.21
10	0.49	8.70	1.18	9.60	15.01	1.48	12.80	20.02	1.94	17.50	27.37	3.00	24.37
15	0.59	10.30	1.19	11.20	17.52	1.49	15.10	23.62	1.97	20.60	32.22	4.50	27.72
30	0.77	12.90	1.20	14.20	22.21	1.49	18.90	29.56	1.98	25.50	39.88	9.00	30.88
60	1.00	16.30	1.20	18.00	28.15	1.49	23.60	36.91	1.97	31.40	49.11	18.00	31.11
120	1.25	20.50	1.19	22.80	35.66	1.47	29.60	46.29	1.93	38.80	60.68	36.00	24.68
240	1.57	25.80	1.18	28.90	45.20	1.46	37.00	57.87	1.88	47.90	74.92	72.00	2.92
360	1.79	29.60	1.18	33.20	51.92	1.44	42.10	65.84	1.85	54.20	84.77	108.00	0.00
600	2.13	35.00	1.18	39.00	61.00	1.43	49.30	77.11	1.81	63.00	98.53	180.00	0.00
1440	2.86	47.00	1.16	53.20	83.20	1.39	65.90	103.07	1.74	82.60	129.19	432.00	0.00

* Z2 is a growth factor from M5 rainfalls



Greenfield runoff rate estimation for sites

www.uksuds.com | Greenfield runoff tool

Calculated by:	John O'Reilly
Site name:	Chapel Lane
Site location:	Cootehill

Site Details

Latitude:	54.07470° N
Longitude:	7.08388° W
Reference:	1173539234
Date:	Oct 13 2023 10:38

This is an estimation of the greenfield runoff rates that are used to meet normal best practice criteria in line with Environment Agency guidance "Rainfall runoff management for developments", SC030219 (2013), the SuDS Manual C753 (Ciria, 2015) and the non-statutory standards for SuDS (Defra, 2015). This information on greenfield runoff rates may be the basis for setting consents for the drainage of surface water runoff from sites.

Runoff estimation approach IH124

Site characteristics

Total site area (ha): 0.25

Methodology

Q _{BAR} estimation method:	Calculate from SPR and SAAR
SPR estimation method:	Calculate from SOIL type

Notes

(1) Is Q_{BAR} < 2.0 l/s/ha?

When Q_{BAR} is < 2.0 l/s/ha then limiting discharge rates are set at 2.0 l/s/ha.

Soil characteristics

	Default	Edited
SOIL type:	4	4
HOST class:	N/A	N/A
SPR/SPRHOST:	0.47	0.47

(2) Are flow rates < 5.0 l/s?

Where flow rates are less than 5.0 l/s consent for discharge is usually set at 5.0 l/s if blockage from vegetation and other materials is possible. Lower consent flow rates may be set where the blockage risk is addressed by using appropriate drainage elements.

Hydrological characteristics

	Default	Edited
SAAR (mm):	1013	1013
Hydrological region:	13	13
Growth curve factor 1 year:	0.85	0.85
Growth curve factor 30 years:	1.65	1.65
Growth curve factor 100 years:	1.95	1.95
Growth curve factor 200 years:	2.15	2.15

(3) Is SPR/SPRHOST ≤ 0.3?

Where groundwater levels are low enough the use of soakaways to avoid discharge offsite would normally be preferred for disposal of surface water runoff.

Greenfield runoff rates

	Default	Edited
Q _{BAR} (l/s):	1.86	1.86
1 in 1 year (l/s):	1.58	1.58
1 in 30 years (l/s):	3.07	3.07
1 in 100 year (l/s):	3.63	3.63
1 in 200 years (l/s):	4	4

This report was produced using the greenfield runoff tool developed by HR Wallingford and available at www.uksuds.com. The use of this tool is subject to the UK SuDS terms and conditions and licence agreement, which can both be found at www.uksuds.com/terms-and-conditions.htm. The outputs from this tool are estimates of greenfield runoff rates. The use of these results is the responsibility of the users of this tool. No liability will be accepted by HR Wallingford, the Environment Agency, CEH, Hydrosolutions or any other organisation for the use of this data in the design or operational characteristics of any drainage scheme.

We use cookies on this site to enhance your user experience

By clicking the Accept button, you agree to us doing so.

OK, I AGREE

MORE INFO

Met Eireann
Return Period Rainfall Depths for sliding Durations
Irish Grid: Easting: 260003, Northing: 314322,

DURATION	Interval		Years										
	6months,	1year,	2,	3,	4,	5,	10,	20,	30,	50,	75,	100,	120,
5 mins	2.5,	3.4,	3.9,	4.7,	5.2,	5.6,	6.9,	8.3,	9.2,	10.5,	11.7,	12.6,	13.2,
10 mins	3.4,	4.8,	5.5,	6.5,	7.2,	7.8,	9.6,	11.5,	12.8,	14.7,	16.3,	17.5,	18.4,
15 mins	4.1,	5.6,	6.4,	7.7,	8.5,	9.2,	11.2,	13.6,	15.1,	17.3,	19.2,	20.6,	21.6,
30 mins	5.4,	7.3,	8.4,	9.9,	10.9,	11.7,	14.2,	17.1,	18.9,	21.5,	23.7,	25.5,	26.6,
1 hours	7.1,	9.5,	10.8,	12.7,	14.0,	14.9,	18.0,	21.4,	23.6,	26.7,	29.4,	31.4,	32.8,
2 hours	9.4,	12.4,	14.0,	16.4,	17.9,	19.1,	22.8,	26.9,	29.6,	33.2,	36.4,	38.8,	40.4,
3 hours	11.0,	14.5,	16.3,	19.0,	20.7,	22.0,	26.2,	30.8,	33.7,	37.7,	41.2,	43.9,	45.7,
4 hours	12.4,	16.2,	18.2,	21.0,	22.9,	24.4,	28.9,	33.8,	37.0,	41.3,	45.1,	47.9,	49.8,
6 hours	14.5,	18.9,	21.2,	24.4,	26.5,	28.1,	33.2,	38.7,	42.1,	46.9,	51.1,	54.2,	56.3,
9 hours	17.1,	22.1,	24.6,	28.3,	30.6,	32.4,	38.1,	44.2,	48.0,	53.3,	57.9,	61.3,	63.6,
12 hours	19.2,	24.7,	27.4,	31.4,	33.9,	35.9,	42.0,	48.6,	52.7,	58.4,	63.2,	66.9,	69.3,
18 hours	22.6,	28.8,	31.9,	36.3,	39.2,	41.4,	48.2,	55.5,	60.1,	66.3,	71.7,	75.7,	78.3,
24 hours	25.4,	32.1,	35.5,	40.3,	43.5,	45.8,	53.2,	61.0,	65.9,	72.6,	78.3,	82.6,	85.4,
2 days	32.1,	39.8,	43.6,	49.0,	52.4,	55.0,	62.9,	71.3,	76.5,	83.5,	89.5,	93.9,	96.8,
3 days	37.9,	46.4,	50.6,	56.4,	60.1,	62.8,	71.4,	80.3,	85.8,	93.1,	99.4,	104.0,	107.1,
4 days	43.2,	52.4,	56.8,	63.0,	67.0,	69.9,	79.0,	88.4,	94.1,	101.9,	108.3,	113.2,	116.4,
6 days	52.7,	63.1,	68.1,	75.1,	79.5,	82.7,	92.7,	102.9,	109.2,	117.5,	124.5,	129.7,	133.1,
8 days	61.4,	72.9,	78.4,	86.0,	90.8,	94.3,	105.1,	116.1,	122.8,	131.7,	139.1,	144.6,	148.2,
10 days	69.7,	82.2,	88.1,	96.3,	101.4,	105.2,	116.7,	128.3,	135.5,	144.9,	152.7,	158.5,	162.3,
12 days	77.6,	91.0,	97.3,	106.0,	111.4,	115.5,	127.6,	139.9,	147.4,	157.3,	165.5,	171.6,	175.5,
16 days	92.7,	107.7,	114.8,	124.4,	130.5,	134.9,	148.3,	161.7,	169.9,	180.6,	189.5,	196.0,	200.2,
20 days	107.2,	123.7,	131.4,	141.9,	148.4,	153.3,	167.7,	182.2,	191.0,	202.4,	211.9,	218.8,	223.3,
25 days	124.7,	142.9,	151.3,	162.8,	169.9,	175.2,	190.8,	206.5,	215.9,	228.2,	238.4,	245.8,	250.7,

NOTES:

These values are derived from a Depth Duration Frequency (DDF) Model update 2023

For details refer to:

'Mateus C., and Coonan, B. 2023. Estimation of point rainfall frequencies in Ireland. Technical Note No. 68. Met Eireann',

Available for download at:

<http://hdl.handle.net/2262/102417>

Technical Specification

Control Point	Head (m)	Flow (l/s)
Primary Design	0.900	5.000
Flush-Flo™	0.271	4.993
Kick-Flo®	0.590	4.110
Mean Flow		4.327

Hydro-Brake® Optimum Flow Control including:

- 3 mm grade 304L stainless steel
- Integral stainless steel pivoting by-pass door allowing clear line of sight through to outlet, c/w stainless steel operating rope
- Beed blasted finish to maximise corrosion resistance
- Stainless steel fixings
- Rubber gasket to seal outlet
- Indicative Weight: 20 kg



hydro-int.com/patents

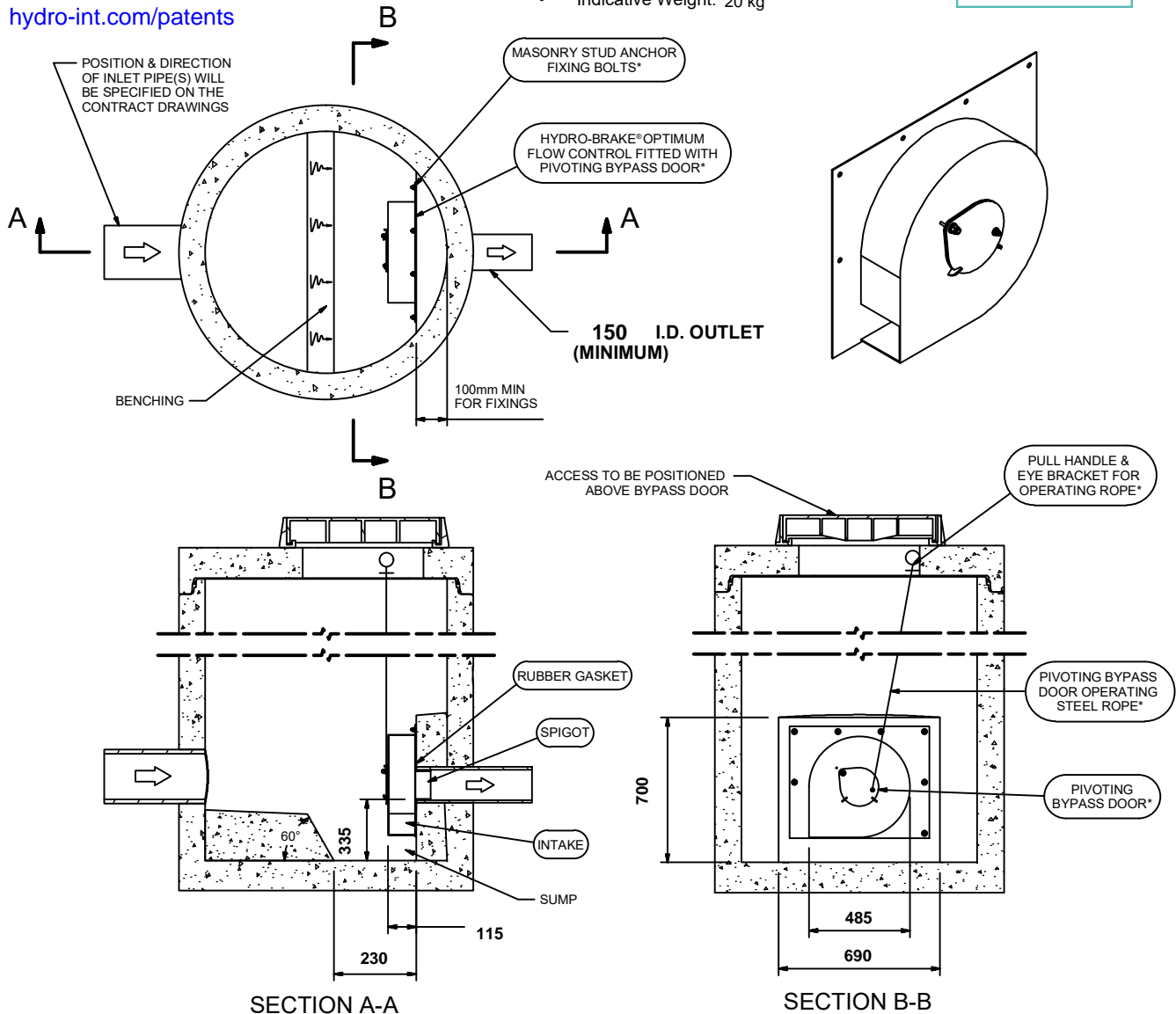

IMPORTANT: ○ LIMIT OF HYDRO INTERNATIONAL SUPPLY
 THE DEVICE WILL BE HANDED TO SUIT SITE CONDITIONS
 FOR SITE SPECIFIC DETAILS AND MINIMUM CHAMBER SIZE REFER TO HYDRO INTERNATIONAL
 ALL CIVIL AND INSTALLATION WORK BY OTHERS
 * WHERE SUPPLIED
 HYDRO-BRAKE® FLOW CONTROL & HYDRO-BRAKE® OPTIMUM FLOW CONTROL ARE REGISTERED TRADEMARKS FOR FLOW CONTROLS DESIGNED AND MANUFACTURED EXCLUSIVELY BY HYDRO INTERNATIONAL

THIS DESIGN LAYOUT IS FOR ILLUSTRATIVE PURPOSES ONLY. NOT TO SCALE.

DESIGN ADVICE



The head/flow characteristics of this SHE-0107-5000-0900-5000 Hydro-Brake® Optimum Flow Control are unique. Dynamic hydraulic modelling evaluates the full head/flow characteristic curve.
The use of any other flow control will invalidate any design based on this data and could constitute a flood risk.

Hydro International
 A CRH COMPANY

DATE	19/10/2023 14:01
SITE	Chapel Lane
DESIGNER	Liam McElgunn
REF	23-121

SHE-0107-5000-0900-5000
 Hydro-Brake® Optimum

Technical Specification

Control Point	Head (m)	Flow (l/s)
Primary Design	0.900	5.000
Flush-Flo	0.271	4.993
Kick-Flo®	0.590	4.110
Mean Flow		4.327



hydro-int.com/patents

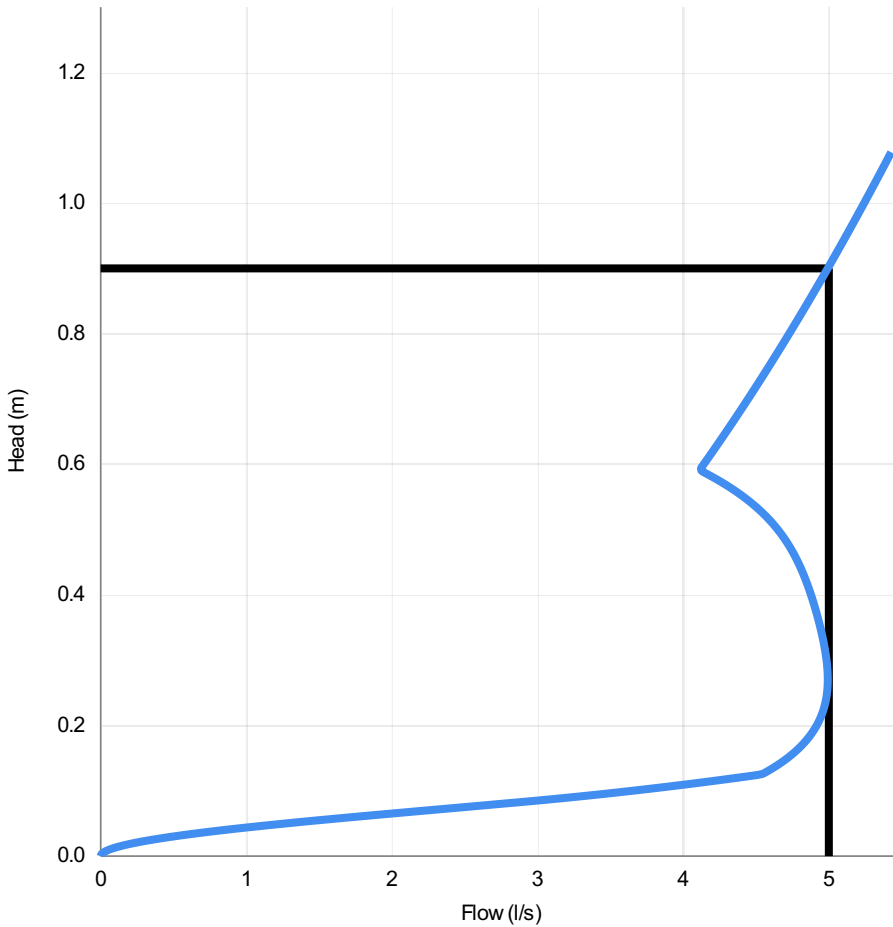

Head (m)	Flow (l/s)
0.000	0.000
0.031	0.529
0.062	1.842
0.093	3.364
0.124	4.529
0.155	4.744
0.186	4.877
0.217	4.952
0.248	4.987
0.279	4.992
0.310	4.978
0.341	4.951
0.372	4.915
0.403	4.872
0.434	4.820
0.466	4.753
0.497	4.661
0.528	4.536
0.559	4.361
0.590	4.127
0.621	4.206
0.652	4.301
0.683	4.394
0.714	4.485
0.745	4.574
0.776	4.661
0.807	4.746
0.838	4.830
0.869	4.912
0.900	4.992

DESIGN ADVICE

The head/flow characteristics of this SHE-0107-5000-0900-5000 Hydro-Brake Optimum® Flow Control are unique. Dynamic hydraulic modelling evaluates the full head/flow characteristic curve.



The use of any other flow control will invalidate any design based on this data and could constitute a flood risk.



DATE	19/10/2023 14:01
Site	Chapel Lane
DESIGNER	Liam McElgunn
Ref	23-121

SHE-0107-5000-0900-5000
Hydro-Brake Optimum®



Modular Geo-Void Systems

Total Water Management

ESS EcoCell

Ecological Tank Systems

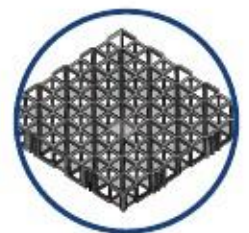
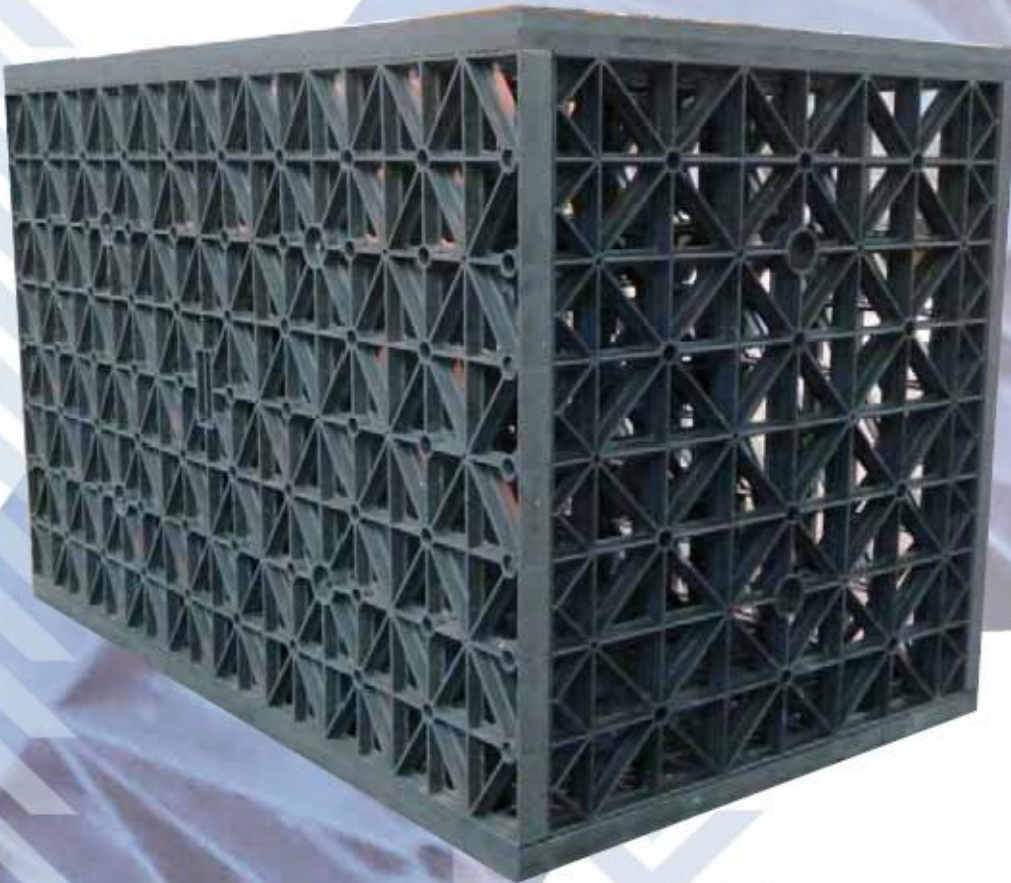

ENVIRONMENTAL SUSTAINABLE SOLUTIONS LTD

Environmental Sustainable Solutions

Welcome to Environmental Sustainable Solutions; specialist suppliers and designers of geocomposites and water re-use systems. Environmental Sustainable Solutions can help you achieve innovative results for all your requirements:-

- ⊗ Stormwater Management
- ⊗ Gas Barrier Protection
- ⊗ Stormwater Attenuation
- ⊗ Contaminated Land Development
- ⊗ Stormwater Drainage
- ⊗ Ground Stabilisation
- ⊗ Rainwater Recycling Management
- ⊗ Structural Waterproofing
- ⊗ Gas Venting Systems
- ⊗ Damp-proofing projects

Over the last 12 years Environmental Sustainable Solutions, and associated companies, have designed and installed thousands of water recycling, drainage and attenuation tank systems for schools, car parks, retail parks, offices and sports arenas throughout Ireland, UK, Europe and the Middle East.

Our wide range of environmental protection products, surface water drainage modules and modular water storage tank systems provides maximum design flexibility for engineers and architects working on even the most demanding of storm water storage and recycling projects.

Stormwater Management And Design

Stormwater is the phrase used to describe the excess rainwater that flows from rooftops, roads, car parks and other buildings. This water can contain many pollutants picked up from roofs and highways. In extreme weather conditions sudden heavy downpours of rain can cause major environmental disasters. Using our Rainmanager products; stormwater can not only safely be removed, but it can be stored and recycled for commercial and domestic use.

How it works

- ESS Attenuation Tank

Stormwater enters the attenuation tank via the inlet manhole, which incorporates a silt collection sump and a galvanised leaf collection basket. Water passes through the tank and exits through the outlet manhole, which contains an AquaBrake flow control device.

This flow control device regulates the release rate of water from the tank, and in so doing, enables the tank to fill. As a result of water entering the tank at a greater rate than it can exit, the void space then fills with water. While the tank fills, air is vented from the tank.

The Inlet/Outlet pipe will act as a flushing channel. This perforated pipe is wrapped completely in High Flow Filtering Geotextile, which prevents silt entering the block area. As the tank continues to empty at a pre-determined rate, air re-enters the tank via the same air vent system. The roof of the completed tank must be lower than the lowest gully trap on site.

Benefits

- ⊗ 100% sealed tank
- ⊗ Full installation service provided
- ⊗ 12 years experience as market leader
- ⊗ Quick installation – reduce site access delays
- ⊗ Increased land usage – tanks are sub surface
- ⊗ Economical – generally more cost efficient than any other equivalent sealed tank
- ⊗ Cost effective – reduced costs for excavation and disposal of material
- ⊗ Modular – easy to create any shape
- ⊗ Strong – designed to support shear loading
- ⊗ Lightweight – no cranes required
- ⊗ Determinate volume – one cubic metre of matrix tank modules contain 950 litres of water, whereas stone fill will only provide 300 litres of storage per cubic metre.

Soakaway

The soakaway is normally best built as a long narrow structure.

The inlet pipe comes in at roof level and faces downwards so that the water can percolate into the tank.

The blocks are wrapped in Geotextile, to protect them and also to keep clay from filling up the void.

An air vent pipe is installed on the highest point with a cowl on top or vented back to an inlet manhole.

There is no outlet from a soakaway, therefore no flow control unit is required.

Protecting the Environment

Stormwater Storage Tank

SUITABLE FOR USE UNDER:

- Roadways
- Car parks
- Green areas

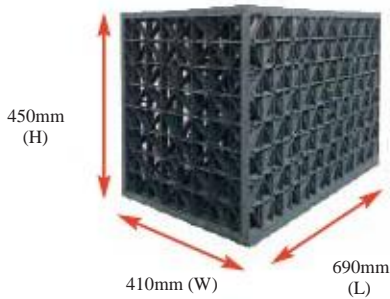

Single
8 Modules/m³
Flowrate - 2300 l/min

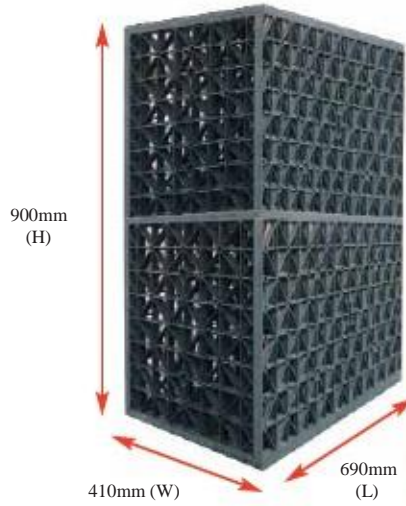

Double
4 Modules/m³
Flowrate - 4600 l/min



Triple
2.6 Modules/m³
Flowrate - 6900 l/min

Notes:

Blocks must be positioned in the correct orientation.
See opposite above

SPECIFICATION (SINGLE)

Weight (maximum)	9.17kg
Crush Strength (up to)	400kN/m ²
Lateral Strength	80kN/m ²
Minimum Cover (green areas)	500mm
(trafficked areas)	650mm
Maximum Cover	3m
Material	Polypropylene
Void Ratio (Internal)	>95%

Design Requirements:

- Tank storage capacity (m³)
- Depth restrictions
- Location (Road, Car Park, Green Area)
- Design constraints on site

DESIGN CRITERIA

The attenuation tank is constructed using matrix module blocks. These blocks can take passing loads of up to 40 tonnes/m². The void ratio of each block is 95%. The blocks are made from polypropylene.

The tank is sealed with a layer of Tuflex membrane, which is fully welded together to form a 100% seal. All pipe penetrations are fully sealed to the membrane. The Tuflex membrane is protected by a layer of heavy duty protection geotextile, to prevent damage from construction or backfilling. A number of air extraction vents/flushing points are placed in the roof of the tank.

Note:

It is vital that the underground tanks are fully sealed, otherwise ground water and silt particles may enter the void space and use up capacity. Preferably, the base of the tank should be 500mm above the ground water level. Otherwise ground water relief measures should be implemented.

A set of loading calculations specific to the site requirement will be done by ESS and submitted on all tanks

Infiltration Swales & Underground Channels

Please refer to separate data sheets for the following products

Modular VersaVoid System



Benefits

G Quick

Reduce site access delays

G Lightweight

No cranes required

G Strong

Designed for maximum anticipated loads

G Maintenance Free Tank

All debris and sediment is pre-filtered

G Determinate Volume

One cubic metre of Tank modules contain 950 litres of water

G Cost Effective

Reduces excavation and disposal by up to 5 x compared with conventional soak wells

G High Infiltration

98% void surface area

G Totally Modular

For greatest flexibility designed to cope. Units start at 300mm deep

for shallow inverts to 3050mm+ deep in 250mm increments.

G Designed by Engineers for Engineers – to specify with confidence.

G Designing out Problems

with such systems (access, maintenance, loading etc.)

G Designing in Answers

to design requirements.

G Total 3D Access

For total maintenance with total confidence.

G Structurally Designed

with built in safety factor to carry all loads with complete confidence.

16 clear vertical access chambers per m².

G Total Void Creation

With the greatest strength from any modular systems.

Oil Filtration

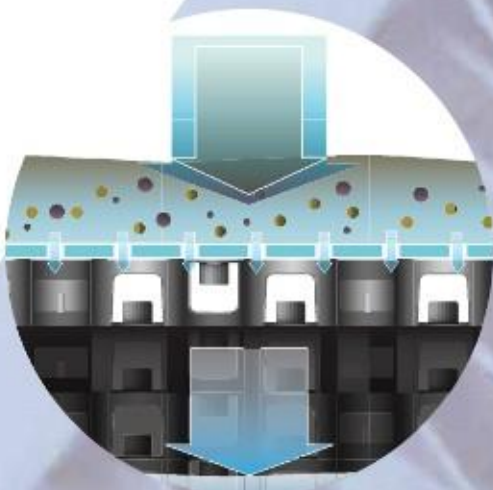

Benefits

G Source control designed to handle catastrophic spillages

G Capture, filter and break down residual hydrocarbons - all in one compact unit

G Self-maintaining ecosystems decompose hydrocarbon compounds and clean filters

G Load bearing, modular components provide up to 200t/m² loading capacity

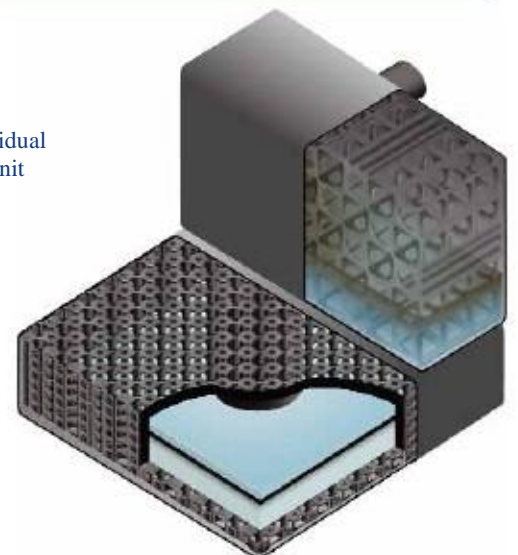

Aquabrake



Benefits

G Cost Savings

Can reduce upstream storage requirements by up to 30%.

G Durability

Corrosion resistant stainless steel.

G No energy requirements

Self-activating solution with no moving parts.

G Clog Resistant

AquaBrake design prevents blockages likely to occur in traditional orifices.

G Flexible Design

Several options for attachment available.

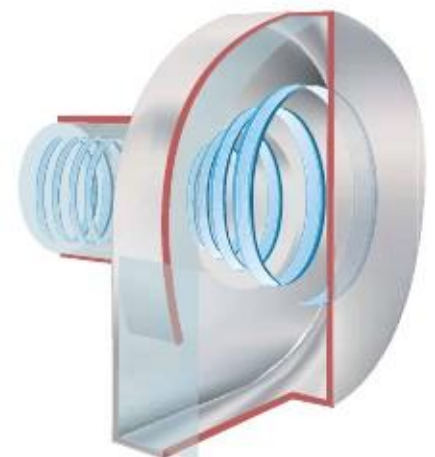

The ESS CombiSwale

Please refer to separate data sheets for the following products

Water Sensitive Urban Channels

Surface and Sub-Surface Water Treatment

By combining surface and sub-surface channeling and treatment solutions, ESS has created the ideal in bioswale water management.

The CombiSwale system includes the addition of permeable sub-surface waterways that further restore water quality and recharge the natural environment. The sub-surface ESS channel system provides a unique way of working with nature to solve the enormous problems currently associated with open concrete channels and swales.

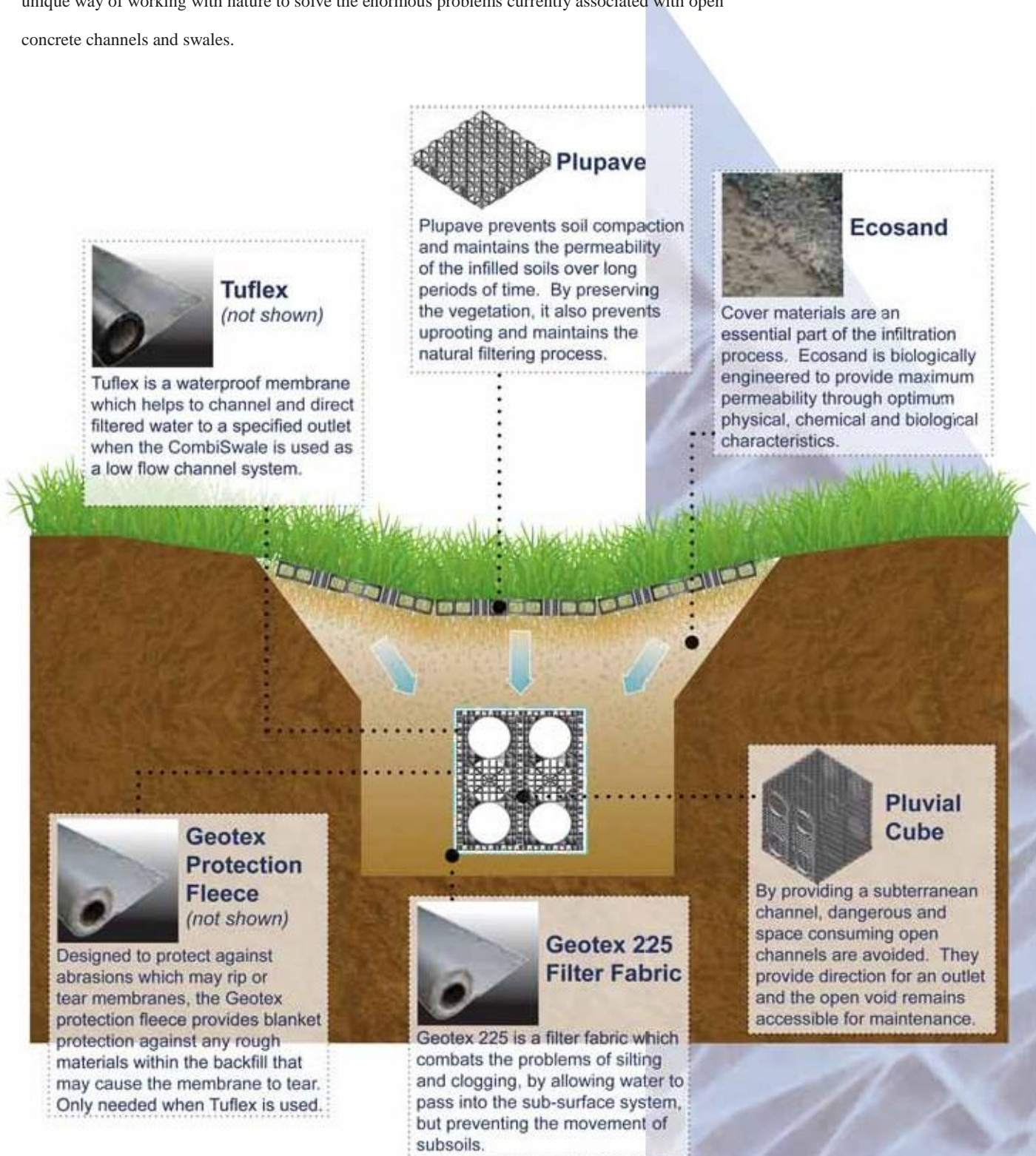

All products are manufactured to the highest quality, being subject to rigid quality control. However, the company cannot control conditions of application and use of its products, thus any warranty, written or implied, is given in good faith for materials only. ESS Ltd will not accept any responsibility for damage or injury arising from storage handling, misapplication or misuse of its products. All transactions are subject to our standard condition of sale, copies of which are available on request.



SEPARATORS

A RANGE OF FUEL/OIL SEPARATORS
FOR PEACE OF MIND



Klargester

The Klargester logo is a blue triangle pointing to the right, containing white wavy lines representing water. The word "Klargester" is written in a red, italicized, sans-serif font across the middle of the triangle.

60 YEARS OF
Expertise &
1955-2015 Innovation



Separators

A RANGE OF FUEL/OIL SEPARATORS FOR PEACE OF MIND

Surface water drains normally discharge to a watercourse or indirectly into underground waters (groundwater) via a soakaway. Contamination of surface water by oil, chemicals or suspended solids can cause these discharges to have a serious impact on the receiving water.

The Environment Regulators, Environment Agency, England and Wales, SEPA, Scottish Environmental Protection Agency in Scotland and Department of Environment & Heritage in Northern Ireland, have published guidance on surface water disposal, which offers a range of means of dealing with pollution both at source and at the point of discharge from site (so called 'end of pipe' treatment). These techniques are known as 'Sustainable Drainage Systems' (SuDS).

Where run-off is draining from relatively low risk areas such as car-parks and non-operational areas, a source control approach, such as permeable surfaces or infiltration trenches, may offer a suitable means of treatment, removing the need for a separator.

Oil separators are installed on surface water drainage systems to protect receiving waters from pollution by oil, which may be present due to minor leaks from vehicles and plant, from accidental spillage.

Effluent from industrial processes and vehicle washing should normally be discharged to the foul sewer (subject to the approval of the sewerage undertaker) for further treatment at a municipal treatment works.

SEPARATOR STANDARDS AND TYPES

A British (and European) standard (EN 858-1 and 858-2) for the design and use of prefabricated oil separators has been adopted. New prefabricated separators should comply with the standard.

SEPARATOR CLASSES

The standard refers to two 'classes' of separator, based on performance under standard test conditions.

CLASS I

Designed to achieve a concentration of less than 5mg/l of oil under standard test conditions, should be used when the separator is required to remove very small oil droplets.

CLASS II

Designed to achieve a concentration of less than 100mg/l oil under standard test conditions and are suitable for dealing with discharges where a lower quality requirement applies (for example where the effluent passes to foul sewer).

Both classes can be produced as full retention separators. The oil concentration limits of 5 mg/l and 100 mg/l are only applicable under standard test conditions. It should not be expected that separators will comply with these limits when operating under field conditions.

FULL RETENTION SEPARATORS

Full retention separators treat the full flow that can be delivered by the drainage system, which is normally equivalent to the flow generated by a rainfall intensity of 65mm/hr.

On large sites, some short term flooding may be an acceptable means of limiting the flow rate and hence the size of full retention systems.

Get in touch for a **FREE** professional site visit and a representative will contact you within 5 working days to arrange a visit.

helpingyou@klargester.com to make the right decision or call **028 302 66799**

BYPASS SEPARATORS

Bypass separators fully treat all flows generated by rainfall rates of up to 6.5mm/hr. This covers over 99% of all rainfall events. Flows above this rate are allowed to bypass the separator. These separators are used when it is considered an acceptable risk not to provide full treatment for high flows, for example where the risk of a large spillage and heavy rainfall occurring at the same time is small.

FORECOURT SEPARATORS

Forecourt separators are full retention separators specified to retain on site the maximum spillage likely to occur on a petrol filling station. They are required for both safety and environmental reasons and will treat spillages occurring during vehicle refuelling and road tanker delivery. The size of the separator is increased in order to retain the possible loss of the contents of one compartment of a road tanker, which may be up to 7,600 litres.

SELECTING THE RIGHT SEPARATOR

The chart on the following page gives guidance to aid selection of the appropriate type of fuel/oil separator for use in surface water drainage systems which discharge into rivers and soakaways.

For further detailed information, please consult the Environment Agency Pollution Prevention Guideline 03 (PPG 3) 'Use and design of oil separators in surface water drainage systems' available from their website.

Kingspan Klargester has a specialist team who provide technical assistance in selecting the appropriate separator for your application.

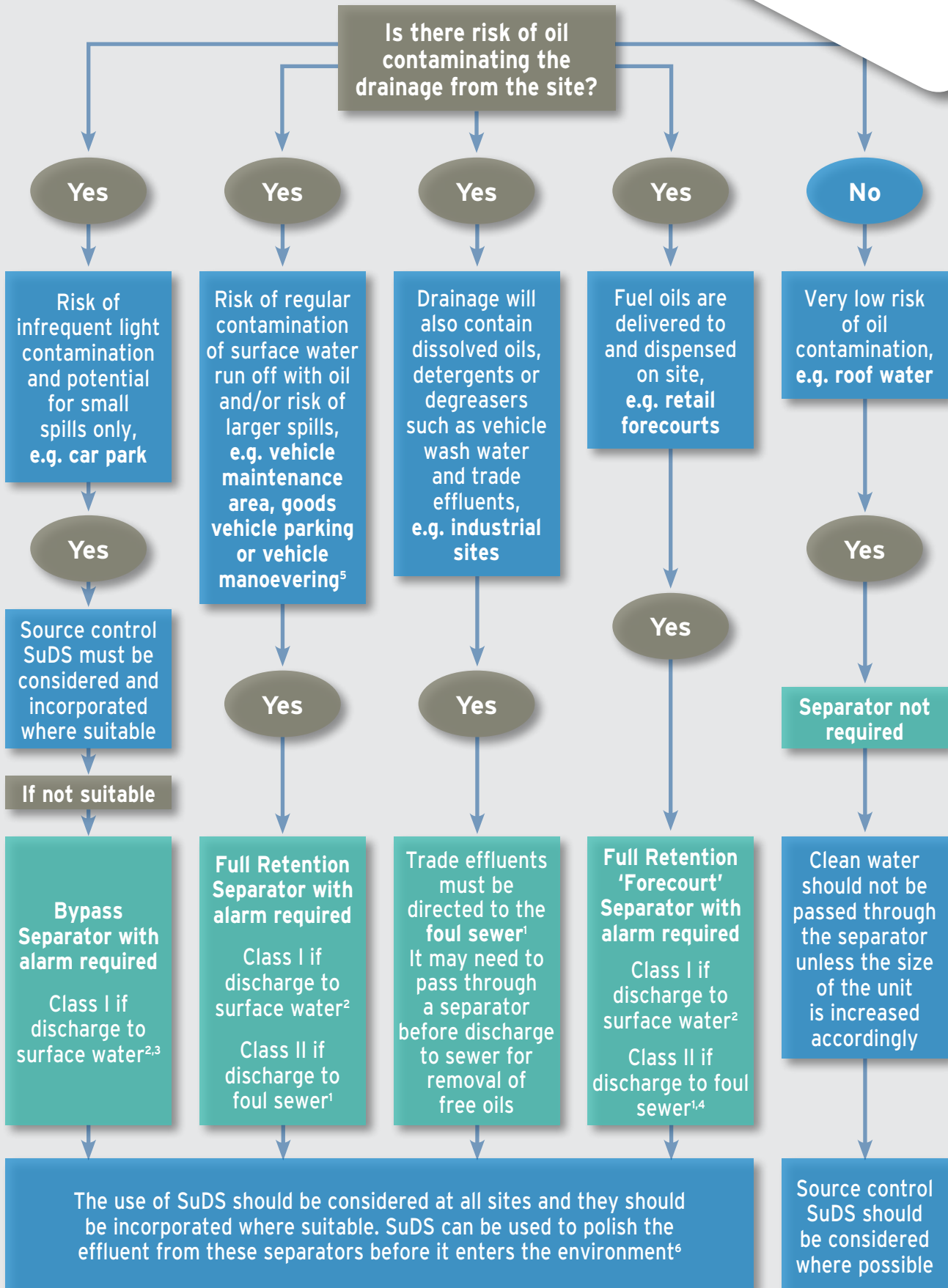

1 You must seek prior permission from your local sewer provider before you decide which separator to install and before you make any discharge.
 2 You must seek prior permission from the relevant environmental body before you decide which separator to install.
 3 In this case, if it is considered that there is a low risk of pollution a source control SuDS scheme may be appropriate.
 4 In certain circumstances, the sewer provider may require a Class 1 separator for discharges to sewer to prevent explosive atmospheres from being generated.
 5 Drainage from higher risk areas such as vehicle maintenance yards and goods vehicle parking areas should be connected to foul sewer in preference to surface water.
 6 In certain circumstances, a separator may be one of the devices used in the SuDS scheme. Ask us for advice.

Bypass NSB RANGE

APPLICATION

Bypass separators are used when it is considered an acceptable risk not to provide full treatment, for very high flows, and are used, for example, where the risk of a large spillage and heavy rainfall occurring at the same time is small, e.g.

- Surface car parks.
- Roadways.
- Lightly contaminated commercial areas.

PERFORMANCE

Klargester were one of the first UK manufacturers to have separators tested to EN 858-1. Klargester have now added the NSB bypass range to their portfolio of certified and tested models. The NSB number denotes the maximum flow at which the separator treats liquids. The British Standards Institute (BSI) tested the required range of Kingspan Klargester Bypass separators and certified their performance in relation to their flow and process performance assessing the effluent qualities to the requirements of EN 858-1. Klargester bypass separator designs follow the parameters determined during the testing of the required range of bypass separators.

Each bypass separator design includes the necessary volume requirements for:

- Oil separation capacity.
- Oil storage volume.
- Silt storage capacity.
- Coalescer.

The unit is designed to treat 10% of peak flow. The calculated drainage areas served by each separator are indicated according to the formula given by PPG3 $NSB = 0.0018A(m^2)$. Flows generated by higher rainfall rates will pass through part of the separator and bypass the main separation chamber.

Class I separators are designed to achieve a concentration of 5mg/litre of oil under standard test conditions.

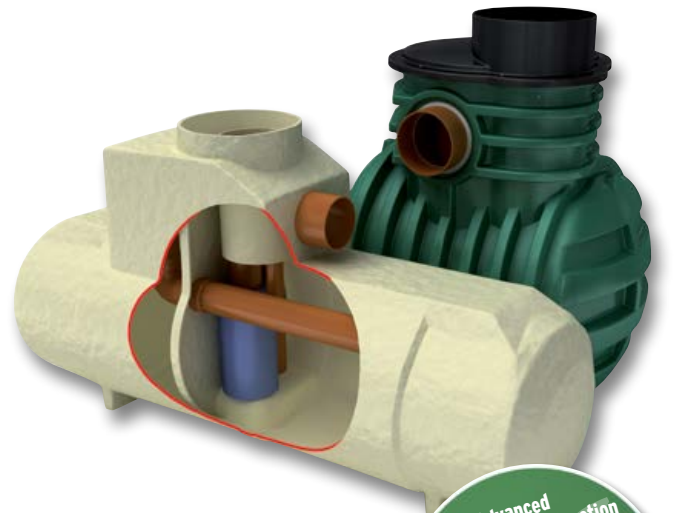

Advanced rotomoulded construction on selected models

- Compact and robust
- Require less backfill
- Tough, lightweight and easy to handle

FEATURES

- Light and easy to install.
- Inclusive of silt storage volume.
- Fitted inlet/outlet connectors.
- Vent points within necks.
- Oil alarm system available (required by EN 858-1 and PPG3).
- Extension access shafts for deep inverts.
- Maintenance from ground level.
- GRP or rotomoulded construction (subject to model).

To specify a nominal size bypass separator, the following information is needed:-

- The calculated flow rate for the drainage area served. Our designs are based on the assumption that any interconnecting pipework fitted elsewhere on site does not impede flow into or out of the separator and that the flow is not pumped.
- The drain invert inlet depth.
- Pipework type, size and orientation.

SIZES AND SPECIFICATIONS

UNIT NOMINAL SIZE	FLOW (l/s)	PEAK FLOW RATE (l/s)	DRAINAGE AREA (m ²)	STORAGE CAPACITY (litres)		UNIT LENGTH (mm)	UNIT DIA. (mm)	ACCESS SHAFT DIA. (mm)	BASE TO INLET INVERT (mm)	BASE TO OUTLET INVERT (mm)	STANDARD FALL ACROSS (mm)	MIN. INLET INVERT (mm)	STANDARD PIPEWORK DIA.
				SILT	OIL								
NSBP003	3	30	1670	300	45	1700	1350	600	1420	1320	100	500	160
NSBP004	4.5	45	2500	450	60	1700	1350	600	1420	1320	100	500	160
NSBP006	6	60	3335	600	90	1700	1350	600	1420	1320	100	500	160
NSBE010	10	100	5560	1000	150	2069	1220	750	1450	1350	100	700	315
NSBE015	15	150	8335	1500	225	2947	1220	750	1450	1350	100	700	315
NSBE020	20	200	11111	2000	300	3893	1220	750	1450	1350	100	700	375
NSBE025	25	250	13890	2500	375	3575	1420	750	1680	1580	100	700	375
NSBE030	30	300	16670	3000	450	4265	1420	750	1680	1580	100	700	450
NSBE040	40	400	22222	4000	600	3230	1920	600	2185	2035	150	1000	500
NSBE050	50	500	27778	5000	750	3960	1920	600	2185	2035	150	1000	600
NSBE075	75	750	41667	7500	1125	5841	1920	600	2235	2035	200	950	675
NSBE100	100	1000	55556	10000	1500	7661	1920	600	2235	2035	200	950	750
NSBE125	125	1250	69444	12500	1875	9548	1920	600	2235	2035	200	950	750

■ Rotomoulded chamber construction ■ GRP chamber construction * Some units have more than one access shaft – diameter of largest shown.

Full Retention NSF RANGE

APPLICATION

Full retention separators are used in high risk spillage areas such as:

- Fuel distribution depots.
- Vehicle workshops.
- Scrap Yards

PERFORMANCE

Kingspan Klargester were the first UK manufacturer to have the required range (3-30 l/sec) certified to EN 858-1 in the UK. The NSF number denotes the flow at which the separator operates.

The British Standards Institute (BSI) have witnessed the performance tests of the required range of separators and have certified their performance, in relation to their flow and process performance to ensure that they met the effluent quality requirements of EN 858-1. Larger separator designs have been determined using the formulas extrapolated from the test range.

Each full retention separator design includes the necessary volume requirements for:

- Oil separation capacity.
- Silt storage capacity.
- Automatic closure device.
- Oil storage volume.
- Coalescer (Class I units only).

Klargester full retention separators treat the whole of the specified flow.

FEATURES

- Light and easy to install.
- Class I and Class II designs.
- 3-30 l/sec range independently tested and performance sampled, certified by the BSI.
- Inclusive of silt storage volume.
- Fitted inlet/outlet connectors.

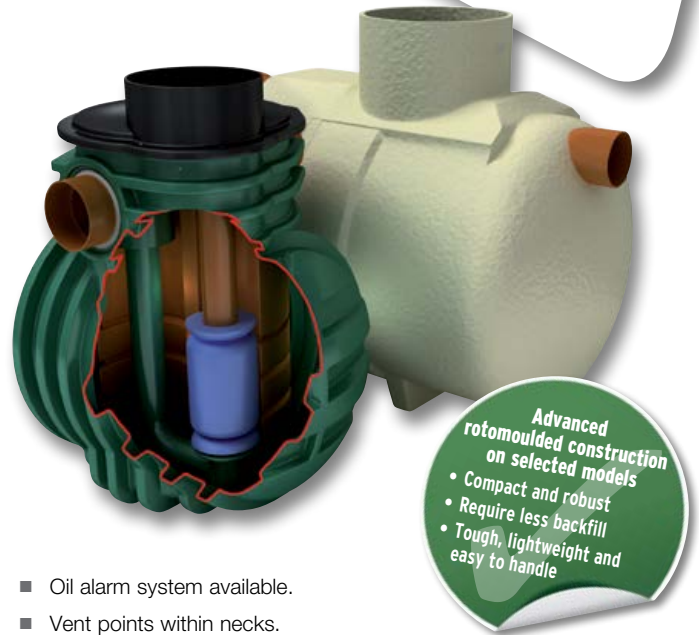

- Oil alarm system available.
- Vent points within necks.
- Extension access shafts for deep inverts.
- Maintenance from ground level.
- GRP or rotomoulded construction (subject to model).

To specify a nominal size full retention separator, the following information is needed:-

- The calculated flow rate for the drainage area served. Our designs are based on the assumption that any interconnecting pipework fitted elsewhere on site does not impede flow into or out of the separator and that the influent is not pumped.
- The required discharge standard. This will decide whether a Class I or Class II unit is required.
- The drain invert inlet depth.
- Pipework type, size and orientation.

SIZES AND SPECIFICATIONS

UNIT NOMINAL SIZE	FLOW (l/s)	DRAINAGE AREA (m ² PPG-3 (0.018))	STORAGE CAPACITY (litres)		UNIT LENGTH (mm)	UNIT DIA. (mm)	BASE TO INLET INVERT (mm)	BASE TO OUTLET INVERT	MIN. INLET INLET (mm)	STANDARD PIPEWORK DIA. (mm)
			SILT	OIL						
NSFP003	3	170	300	30	1700	1350	1420	1345	500	160
NSFP006	6	335	600	60	1700	1350	1420	1345	500	160
NSFA010	10	555	1000	100	2610	1225	1050	1000	500	200
NSFA015	15	835	1500	150	3910	1225	1050	1000	500	200
NSFA020	20	1115	2000	200	3200	2010	1810	1760	1000	315
NSFA030	30	1670	3000	300	3915	2010	1810	1760	1000	315
NSFA040	40	2225	4000	400	4640	2010	1810	1760	1000	315
NSFA050	50	2780	5000	500	5425	2010	1810	1760	1000	315
NSFA065	65	3610	6500	650	6850	2010	1810	1760	1000	315
NSFA080	80	4445	8000	800	5744	2820	2500	2450	1000	300
NSFA100	100	5560	10000	1000	6200	2820	2500	2450	1000	400
NSFA125	125	6945	12500	1250	7365	2820	2500	2450	1000	450
NSFA150	150	8335	15000	1500	8675	2820	2550	2450	1000	525
NSFA175	175	9725	17500	1750	9975	2820	2550	2450	1000	525
NSFA200	200	11110	20000	2000	11280	2820	2550	2450	1000	600

■ Rotomoulded chamber construction ■ GRP chamber construction

Washdown & Silt

APPLICATION

This unit can be used in areas such as car wash and other cleaning facilities that discharge directly into a foul drain, which feeds to a municipal treatment facility.

If emulsifiers are present the discharge must not be allowed to enter an NS Class I or Class II unit.

- Car wash.
- Tool hire depots.
- Truck cleansing.
- Construction compounds cleansing points.

PERFORMANCE

Such wash down facilities must not be allowed to discharge directly into surface water but must be directed to a foul connection leading to a municipal treatment works as they utilise emulsifiers, soaps and detergents, which can dissolve and disperse the oils.

SIZES AND SPECIFICATIONS

REF.	TOTAL CAPACITY (litres)	MAX. REC. SILT	MAX. FLOW RATE (l/s)	LENGTH (mm)	DIAMETER (mm)	ACCESS SHAFT DIA. (mm)	BASE TO INLET INVERT (mm)	BASE TO OUTLET INVERT (mm)	STANDARD FALL ACROSS UNIT (mm)	MIN. INLET INVERT (mm)	STANDARD PIPEWORK DIA. (mm)	APPROX EMPTY (kg)
W1/010	1000	500	3	1123	1225	460	1150	1100	50	500	160	60
W1/020	2000	1000	5	2074	1225	460	1150	1100	50	500	160	120
W1/030	3000	1500	8	2952	1225	460	1150	1100	50	500	160	150
W1/040	4000	2000	11	3898	1225	460	1150	1100	50	500	160	180
W1/060	6000	3000	16	4530	1440	600	1360	1310	50	500	160	320
W1/080	8000	4000	22	3200	2020	600	2005	1955	50	500	160	585
W1/100	10000	5000	27	3915	2020	600	2005	1955	50	500	160	680
W1/120	12000	6000	33	4640	2020	600	2005	1955	50	500	160	770
W1/150	15000	7500	41	5435	2075	600	1940	1890	50	500	160	965
W1/190	19000	9500	52	6865	2075	600	1940	1890	50	500	160	1200

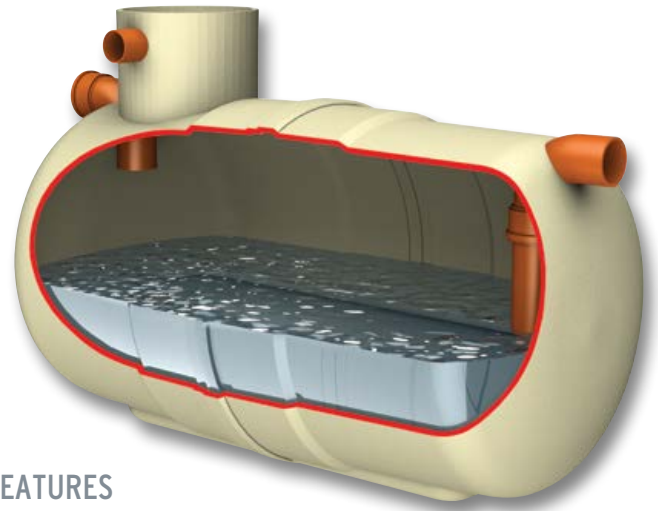

FEATURES

- Light and easy to install.
- Inclusive of silt storage volume.
- Fitted inlet/outlet connectors.
- Vent points within necks.
- Extension access shafts for deep inverts.
- Maintenance from ground level.

Car Wash Silt Trap

APPLICATION

Car Wash silt trap is designed for use before a separator in car wash applications to ensure effective silt removal.

FEATURES

- FACTA Class B covers.
- Light and easy to install.
- Maintenance from ground level.

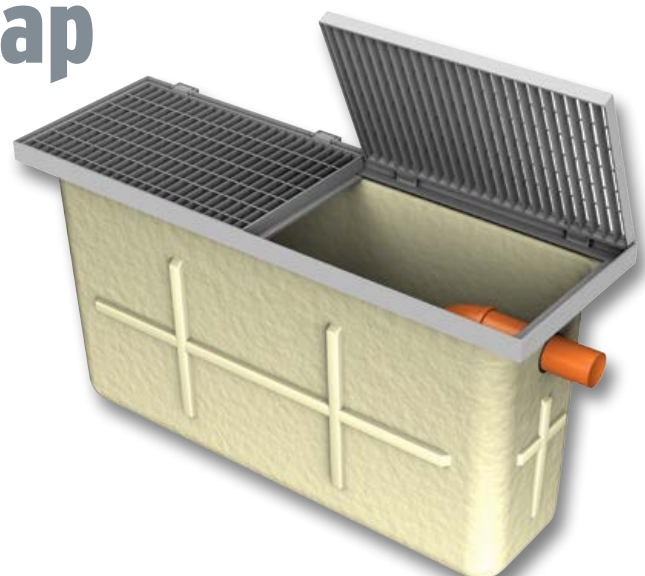

Forecourt

APPLICATION

The forecourt separator is designed for installation in petrol filling station forecourts and similar applications. The function of the separator is to intercept hydrocarbon pollutants such as petroleum and oil and prevent their entry to the drainage system, thus protecting the environment against hydrocarbon contaminated surface water run-off and gross spillage.

PERFORMANCE

Operation ensures that the flow cannot exit the unit without first passing through the coalescer assembly.

In normal operation, the forecourt separator has sufficient capacity to provide storage for separated pollutants within the main chamber, but is also able to contain up to 7,600 litres of pollutant arising from the spillage of a fuel delivery tanker compartment on the petrol forecourt. The separator has been designed to ensure that oil cannot exit the separator in the event of a major spillage, subsequently the separator should be emptied immediately.

FEATURES

- Light and easy to install.
- Inclusive of silt storage volume.
- Fitted inlet/outlet connectors.
- Vent points within necks.
- Extension access shafts for deep inverts.
- Maintenance from ground level.

SIZES AND SPECIFICATIONS

ENVIROCEPTOR CLASS	TOTAL CAP. (litres)	DRAINAGE AREA (m ²)	MAX. FLOW RATE (l/s)	LENGTH (mm)	DIAMETER (mm)	ACCESS SHAFT DIA. (mm)	BASE TO INLET INVERT (mm)	BASE TO OUTLET INVERT (mm)	STD. FALL ACROSS UNIT (mm)	MIN. INLET INVERT (mm)	STD. PIPEWORK (mm)	EMPTY WEIGHT (kg)
I	10000	555	10	3963	1920	600	2110	2060	50	400	160	500
II	10000	555	10	3963	1920	600	2110	2060	50	400	160	500
I	10000	1110	20	3963	1920	600	2110	2060	50	400	200	500
II	10000	1110	20	3963	1920	600	2110	2060	50	400	200	500



- Class I and Class II design.
- Oil storage volume.
- Coalescer (Class I unit only).
- Automatic closure device.
- Oil alarm system available.

INSTALLATION

The unit should be installed on a suitable concrete base slab and surrounded with concrete or pea gravel backfill. See sales drawing for installation.

If the separator is to be installed within a trafficked area, then a suitable cover slab must be designed to ensure that loads are not transmitted to the unit.

The separator should be installed and vented in accordance with Health and Safety Guidance Note HS(G)41 for filling stations, subject to Local Authority requirements.

Alarm Systems

British European Standard EN 858-1 and Environment Agency Pollution Prevention Guideline PPG3 requires that all separators are to be fitted with an oil level alarm system and that it should be installed and calibrated by a suitably qualified technician so that it will respond to an alarm condition when the separator requires emptying.

- Easily fitted to existing tanks.
- Excellent operational range.
- Visual and audible alarm.
- Additional telemetry option.



PROFESSIONAL INSTALLERS

Kingspan Klargester Accredited Installers

Experience shows that correct installation is a prerequisite for the long-lasting and successful operation of any wastewater treatment product. This is why using an installer with the experience and expertise to install your product is highly recommended.



Services include :

- Site survey to establish ground conditions and soil types
- Advice on system design and product selection
- Assistance on gaining environmental consents and building approvals
- Tank and drainage system installation
- Connection to discharge point and electrical networks
- Waste emptying and disposal

Discover more about the Accredited Installers and locate your local expert online.

www.kingspanenviro.com/klargester



CARE & MAINTENANCE

Kingspan Environmental Services

Who better to look after your treatment plant than the people who designed and built it?



Kingspan Environmental have a dedicated service division providing maintenance for wastewater products.

Factory trained engineers are available for site visits as part of a planned maintenance contract or on a one-off call out basis.

To find out more about protecting your investment and ensuring peace of mind, call us on:

0844 846 0500

or visit us online:

www.kingspanenvservice.com



COMMERCIAL WASTEWATER SOLUTIONS

- **BIODISC® & ENVIROSAFE**
HIGH PERFORMANCE SEWAGE TREATMENT SYSTEMS
- PACKAGE PUMP STATIONS
- **PUMPSTOR24** PUMPING SYSTEMS
- OIL/WATER SEPARATORS
- BELOW GROUND STORAGE TANKS
- GREASE & SILT TRAPS

RAINWATER SOLUTIONS

- BELOW GROUND RAINWATER HARVESTING SYSTEMS
- ABOVE GROUND RAINWATER HARVESTING SYSTEMS

Klargester

UK: College Road North, Aston Clinton, Aylesbury, Buckinghamshire HP22 5EW

Tel: +44 (0) 1296 633000 Fax: +44 (0) 1296 633001 Scottish Office: Tel: +44 (0) 1355 248484
email: klargester@kingspan.com

Ireland: Unit 1a, Derryboy Road, Carnbane Business Park, Newry, Co. Down BT35 6QH

NI Tel : +44 (0) 28 302 66799 Fax: +44 (0) 28 302 60046 ROI Tel: 048 302 66799 Fax: 048 302 60046
email: klargesterinfor@kingspan.com

Visit our website www.kingspanenviro.com/klargester



In keeping with Company policy of continuing research and development and in order to offer our clients the most advanced products, Kingspan Environmental reserves the right to alter specifications and drawings without prior notice.

Appendix B – Foul Water Calculations

Foul sewer loadings for housing development at Chapel Lane, Cootehill, Co. Cavan

DATA							SEWER DESIGN Ks = 1.50										
SEWER REFERENCE From Manhole To Manhole		HOUSES No.	UNITS/ HOUSE No.	UNITS No.	TOTAL UNITS l/s	TOTAL FLOW l/s	Size of drain (mm)	Gradient (1 in x)	Length (m)	Capacity (l/sec)	Pipe full Velocity (m/sec)	Actual Velocity (m/sec)	Half full velocity (m/sec)	Self cleansing at half full	Max Velocity (m/sec)	Depth of flow (mm)	Reserve capacity (l/sec)
1	2	3	4	5	6	7	8	9	10	11	12	13	14	15	16	17	18
F1	F2	6	14	84	84	3.813	150	60.0	24.057	20.000	1.132	0.869	1.132	OK	1.291	44.531	16.187
F2	F3	4	14	56	140	4.250	150	60.0	17.407	20.000	1.132	0.896	1.132	OK	1.291	46.875	15.749
F3	F4	3	14	42	182	4.558	150	150.0	56.185	12.612	0.714	0.655	0.714	OK	0.814	62.109	8.054
F4	F5	0	14	0	182	4.558	150	150.0	18.512	12.612	0.714	0.655	0.714	OK	0.814	62.109	8.054
F5	F6	0	14	0	182	4.558	150	150.0	20.947	12.612	0.714	0.655	0.714	OK	0.814	62.109	8.054
F6	Fext	0	14	0	182	4.558	150	21.0	62.652	33.876	1.917	1.330	1.917	OK	2.186	37.500	29.318



Foul Discharge Design Calculations

The following calculations are in accordance with Appendix C 'Wastewater Flow Rates for Design' of Irish Water Code of Practice for Wastewater Infrastructure. (IW-CDS_5030-03)

Domestic Dwelling - Flow Rate = 150 litres/occupant/day

Peak Design Flow Rate = 6 x Domestic Flow Rate

Project Name:	Chapel Lane
Project Number:	23-121

1 Bed Unit = Max	2 persons
2 Bed Unit = Max	3 persons
3 Bed Unit = Max	5 persons
4 Bed Unit = Max	6 persons

1 Bed Units =	9
Flow Rate =	0.0035 l/s per unit
Peak Design Flow Rate =	0.0208 l/s per unit
Total Flow from 9 Units =	0.188 l/s

2 Bed Units =	1
Flow Rate =	0.0052 l/s per unit
Peak Design Flow Rate =	0.0313 l/s per unit
Total Flow from 1 Units =	0.031 l/s

3 Bed Units =	3
Flow Rate =	0.0087 l/s per unit
Peak Design Flow Rate =	0.0521 l/s per unit
Total Flow from 3 Units =	0.156 l/s

4 Bed Units =	0
Flow Rate =	0.0000 l/s per unit
Peak Design Flow Rate =	0.0000 l/s per unit
Total Flow from 0 Units =	0.000 l/s

Total Flow From Development (13 Units)(36 Persons) = 5400 litres or 5.4 m³/day

Peak Design Flow Rate = 0.375 l/s

Average Discharge = 0.0625 l/s

Appendix C – Irish Water Confirmation of Feasibility

CONFIRMATION OF FEASIBILITY

Marc McBride

Alan Traynor Consulting Engineers
Belturbet Business Park
Creeny
Belturbet
Co. Cavan

24 July 2023

Uisce Éireann
Bosca OP 448
Oifig Sheachadta na
Cathrach Theas
Cathair Chorcaí

Irish Water
PO Box 448,
South City
Delivery Office,
Cork City.

www.water.ie

Our Ref: CDS23003539 Pre-Connection Enquiry
Chapel Lane, Cootehill, Co. Cavan

Dear Applicant/Agent,

We have completed the review of the Pre-Connection Enquiry.

Irish Water has reviewed the pre-connection enquiry in relation to a Water & Wastewater connection for a Housing Development of 10 unit(s) at Chapel Lane, Cootehill, Cootehill, Cavan, (the **Development**).

Based upon the details provided we can advise the following regarding connecting to the networks;

- **Water Connection** - **Feasible Subject to upgrades**
 - an approximate 130m network extension from the existing 150mm dia watermain located on bridge street will be required to serve this development.

Please note, while flows in excess of your required demand may be achieved in the Uisce Éireann network and could be utilised in the event of a fire, Uisce Éireann cannot guarantee a flow rate to meet your fire flow requirement. To guarantee a flow to meet the Fire Authority requirements you should provide adequate fire storage capacity within your development.

- **Wastewater Connection** - **Feasible Subject to upgrades**

- an approximate 150m network extension would be required to service this development. Connection, as proposed, to foul sewer SH60141301 to the north-east of the site at the junction of chapel lane and Bellamont view.

This letter does not constitute an offer, in whole or in part, to provide a connection to any Irish Water infrastructure. Before the Development can be connected to our network(s) you must submit a connection application and be granted and sign a connection agreement with Irish Water.

As the network capacity changes constantly, this review is only valid at the time of its completion. As soon as planning permission has been granted for the Development, a completed connection application should be submitted. The connection application is available at www.water.ie/connections/get-connected/

Where can you find more information?

- **Section A** - What is important to know?
- **Section B** - Details of Irish Water's Network(s)

This letter is issued to provide information about the current feasibility of the proposed connection(s) to Irish Water's network(s). This is not a connection offer and capacity in Irish Water's network(s) may only be secured by entering into a connection agreement with Irish Water.

For any further information, visit www.water.ie/connections, email newconnections@water.ie or contact 1800 278 278.

Yours sincerely,

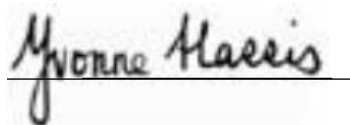

Yvonne Harris
Head of Customer Operations

Section A - What is important to know?

What is important to know?	Why is this important?
Do you need a contract to connect?	<ul style="list-style-type: none"> • Yes, a contract is required to connect. This letter does not constitute a contract or an offer in whole or in part to provide a connection to Irish Water's network(s). • Before the Development can connect to Irish Water's network(s), you must submit a connection application <u>and be granted and sign</u> a connection agreement with Irish Water.
When should I submit a Connection Application?	<ul style="list-style-type: none"> • A connection application should only be submitted after planning permission has been granted.
Where can I find information on connection charges?	<ul style="list-style-type: none"> • Irish Water connection charges can be found at: https://www.water.ie/connections/information/charges/
Who will carry out the connection work?	<ul style="list-style-type: none"> • All works to Irish Water's network(s), including works in the public space, must be carried out by Irish Water*. <p>*Where a Developer has been granted specific permission and has been issued a connection offer for Self-Lay in the Public Road/Area, they may complete the relevant connection works</p>
Fire flow Requirements	<ul style="list-style-type: none"> • The Confirmation of Feasibility does not extend to fire flow requirements for the Development. Fire flow requirements are a matter for the Developer to determine. • What to do? - Contact the relevant Local Fire Authority
Plan for disposal of storm water	<ul style="list-style-type: none"> • The Confirmation of Feasibility does not extend to the management or disposal of storm water or ground waters. • What to do? - Contact the relevant Local Authority to discuss the management or disposal of proposed storm water or ground water discharges.
Where do I find details of Irish Water's network(s)?	<ul style="list-style-type: none"> • Requests for maps showing Irish Water's network(s) can be submitted to: datarequests@water.ie

<p>What are the design requirements for the connection(s)?</p>	<ul style="list-style-type: none"> The design and construction of the Water & Wastewater pipes and related infrastructure to be installed in this Development shall comply with <i>the Irish Water Connections and Developer Services Standard Details and Codes of Practice</i>, available at www.water.ie/connections
<p>Trade Effluent Licensing</p>	<ul style="list-style-type: none"> Any person discharging trade effluent** to a sewer, must have a Trade Effluent Licence issued pursuant to section 16 of the Local Government (Water Pollution) Act, 1977 (as amended). More information and an application form for a Trade Effluent License can be found at the following link: https://www.water.ie/business/trade-effluent/about/ <p>**trade effluent is defined in the Local Government (Water Pollution) Act, 1977 (as amended)</p>

Section B – Details of Irish Water’s Network(s)

The map included below outlines the current Irish Water infrastructure adjacent the Development: To access Irish Water Maps email datarequests@water.ie



Reproduced from the Ordnance Survey of Ireland by Permission of the Government. License No. 3-3-34

Note: The information provided on the included maps as to the position of Irish Water’s underground network(s) is provided as a general guide only. The information is based on the best available information provided by each Local Authority in Ireland to Irish Water.

Whilst every care has been taken in respect of the information on Irish Water’s network(s), Irish Water assumes no responsibility for and gives no guarantees, undertakings or warranties concerning the accuracy, completeness or up to date nature of the information provided, nor does it accept any liability whatsoever arising from or out of any errors or omissions. This information should not be solely relied upon in the event of excavations or any other works being carried out in the vicinity of Irish Water’s underground network(s). The onus is on the parties carrying out excavations or any other works to ensure the exact location of Irish Water’s underground network(s) is identified prior to excavations or any other works being carried out. Service connection pipes are not generally shown but their presence should be anticipated.